

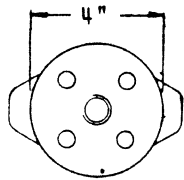

PART NO.	PART NAME	MATERIAL	MATERIAL SPEC.	QTY. PER UNIT	REF. NO.
1	BACK COVER, COMPL. (1)	CAST ALUMINUM	ASTM B-26, GR. S564D	2	36347
2	BOLT, BACK COVER	STEEL, PLATED	COMMERCIAL	12	37274
3	LOCK NUT	STEEL, PLATED	COMMERCIAL	12	37269
4	DIAPHRAGM RING SCREW	STEEL, PLATED	COMMERCIAL	2	34728
5	DIAPHRAGM SET	STAINLESS STEEL	COMMERCIAL	2	27218
6	DIAPHRAGM HOUSING	CAST ALUMINUM	ASTM B-26, GR. S564D	2	34861
7	GASKET	SHEET PACKING	COMMERCIAL	4	24311
8	LOCK WASHER	STEEL, PLATED	COMMERCIAL	6	10392
9	CAP SCREW, HORN	STEEL, PLATED	COMMERCIAL	6	24503
10	#31, HORN COMPLETE (2)	CAST ALUMINUM	ASTM B-26, GR. S5A	1	27576
10	#44, HORN COMPLETE (2)	CAST ALUMINUM	ASTM B-26, GR. S5A	1	27581
11	HORN BASE	CAST ALUMINUM	ASTM B-26, GR. S5A	1	27122

NOTE 1 - INCLUDES DIAPHRAGM RING SCREW, PART NO.4 AND DIAPHRAGM SET, PART NO.5.
 NOTE 2 - INCLUDES ORIFICE DOWEL PIN, .095 REF. NO. 27282, FOR #44 HORN AND
 .109 REF. NO. 27283, FOR #31 HORN.

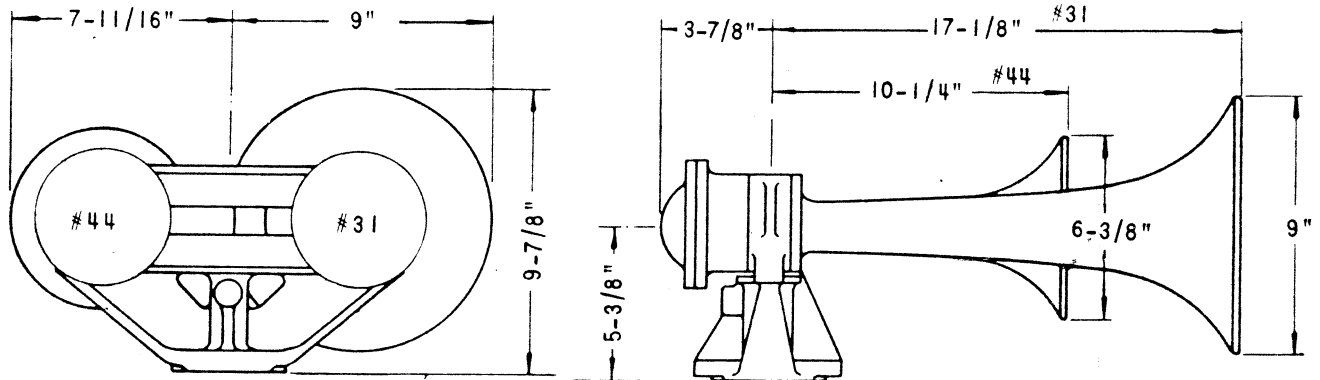

MOUNTING FLANGE

TAPPED IN CENTER FOR 1/2" PIPE FOUR
 9/16" HOLES EQUALLY SPACED AND
 STRADDLING CENTER LINE ON 3" DIAMETER
 BOLT CIRCLE FOR ALL CHIME WHISTLES.



LESLIE CO.

PARSIPPANY NEW JERSEY 07054

LESLIE-SUPERTYFON CHIME WHISTLE
 TYPE S-2M-BO DUAL TONE

DATE	APP'D.	D'W'N	DWG. 001 6597 03
12-4-73	JR	MG	NO. ALT. 0 DD

STLE

AND PULL HORN,
 REPLACING OR
 F THE SMALL

SING, PART NO.
 KETS, PART

D TIGHTEN HORN
 WS.

DRIFICE DOWEL
 EE FACING
 N.